

Électro-aimants de fixation

Elettromagneti di ritenuta

Elektro-Haftmagnete

Electro holding magnets

Electroimanes adherentes

ELECTRO HOLDING MAGNETS





2

Opening up new frontiers, utilising modern technology and effective realisation of innovative ideas. effeff in Albstadt has followed a consistent marketing strategy since the company was founded in 1947, developing to become the market leader today in the field of door control systems. A comprehensive range of products was developed in stages since the commencement of door opener production in 1947, and effeff now provides a broad spectrum of door application system solutions that compliment each other, right down to the last detail. effeff has been a part of the ASSA ABLOY Group since the 1st of February 2000. The group has its headquarters in Stockholm. ASSA ABLOY is the world's leading manufacturer and supplier of mechanical and electromechanical locking system solutions and associated products. effeff



Hamburg Airport



Alte Oper (Old Opera House), Frankfurt



customers thus profit from the comprehensive know-how of the world's largest provider of everything from A to Z for improved comfort and enhanced security.

effeff, the experts for electromechanical security technology, export today to more than 75 countries. The company has over 420 employees and a justifiable reputation as a reliable and competent partner in every sector. The Swabian company places the highest priority on close customer support and service.

Whatever you wish to guard, protect or keep safe – effeff has the technology for your requirements



British Embassy, Berlin



Bodensee-Therme, thermal bathing complex in Überlingen, Lake Constance



CONTENTS

HOW DO I FIND WHAT I NEED?

ABOUT OURSELVES	2 - 3
CONTENTS	5
INTRODUCTION TO MAGNETS	6 - 7
ELECTRO HOLDING MAGNETS	
Micro magnets / 1500 N	8
Mini magnets / 3000 N	9
Twin mini magnets / 2x3000 N	10
Standard magnets / 5000 N	11
Twin standard magnets / 2x5000 N	12
Door and gate magnets / 6500 N	13
Mini shear magnets / 5700 N	14
Standard shear magnets / 15000 N	15
ACCESSORIES FOR ELECTRO HOLDING MAGNETS	
L-shaped mounting brackets	16
Z-shaped mounting brackets	17
General installation accessories	18 - 19
ELECTRO HOLDING MAGNETS IN ESCAPE ROUTES AND MOUNTING ON FIRE PROTECTION DOORS	
Explanation	20
Compact surface holding magnets / 2500 N	21
Compact surface holding magnets / 5000 N	22
Installation drawings	23
ROUND MAGNETS FOR HOLDING DOORS OPEN	
Explanation	24
Examples of wall and floor mountings	25
Electro holding magnets (version A/B/C)	26
Electro holding magnets (version iS/iGW/iGB/U)	27
Spacers	28 - 29
Counter-holding plates	30 - 31
PRODUCT OVERVIEW	32 - 33
ORDER FAX	35



ELECTRO HOLDING MAGNETS

INTRODUCTION

Why should you choose an electro holding magnet from effeff!

A large selection of magnets in a variety of different structural designs is an important component of effeff locking system products.

The effeff range encompasses varied appliances for standard doors. Electro holding magnets are ideally suitable for additional door locking applications, thanks to their functional silence and the special retrofitting advantages they offer.

In addition to these advantages, the effeff range also provides electro holding magnets approved by EltVTR (directive for electrical locking system on escape route doors) that are suitable for use on escape and rescue routes.



Round magnets represents a further product division, being employed for fire protection doors and arrester systems.

Important advantages of surface magnets include:

- their particular installation friendliness
- they are ideal for retrofitting in doors with access control
- different holding power classes make them suitable for installation in the most varied door systems
- practically zero wear, thanks to their structure and functionality

ELECTRO HOLDING MAGNETS

MICRO MAGNETS

1500 N

Utilisation

- Utilisation for locking cabinets and drawers (compact housing)
- Holding power approx. 1500 N

Version for surface mounting

Stainless steel housing surface

Dimensions (L x W x D): 170 x 32 x 24 mm

Order number

MAG-01500STS--A

Version for mortise mounting

Stainless steel housing surface

Dimensions (L x W x D): 200 x 32 x 24 mm

Order number

MAG-01500STM--A



Model MAG-01500STS--A



Model MAG-01500STM--A

8

Technical data

Holding power	approx. 1500 N
Rated operating voltage	12 V DC
Current consumption	350 mA
Connection lead	approx. 90 cm

Suitable accessories*

Order number

L-shaped mounting bracket

MAGAC-L150-----

Z-shaped mounting bracket

MAGAC-Z150-----

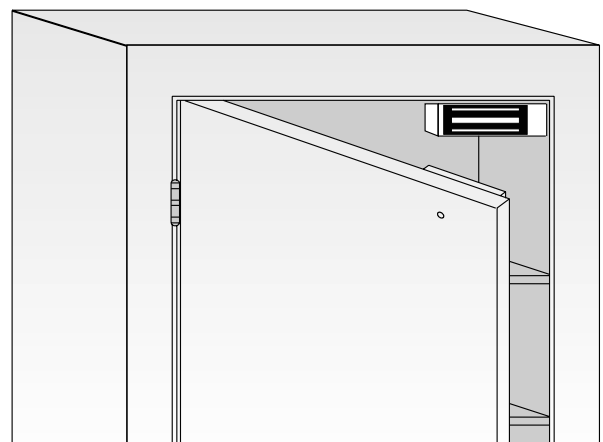

Cabinet mounting example

* More information on accessories from page 16 onwards.

ELECTRO HOLDING MAGNETS

3000 N

MINI MAGNETS

Utilisation

- For locking doors
- Holding power approx. 3000 N

Version for surface mounting

Aluminium housing surface

Dimensions (L x W x D): 250 x 42 x 25 mm

Order number

MAG-03000ALS--D

Aluminium housing surface, hall sensor**

MAG-03000ALS-HD

Version for mortise mounting

Aluminium housing surface

Dimensions (L x W x D): 230 x 38 x 28 mm

Order number

MAG-03000ALM--D

Aluminium housing surface, hall sensor**

MAG-03000ALM-HD

Version for surface mounting

Stainless steel housing surface

Dimensions (L x W x D): 210 x 41 x 26 mm

Order number

MAG-03000STS--A

Version for mortise mounting

Stainless steel housing surface

Dimensions (L x W x D): 227 x 38 x 26 mm

MAG-03000STM--D

Stainless steel housing surface, hall sensor**

MAG-03000STM-HD

Technical data

Holding power	approx. 3000 N
Rated operating voltage	12 or 24 V DC
Rated op. voltage MAG-03000STS--A	12 V DC
Current consumption 12 V DC	500 mA
24 V DC	250 mA
Connection lead	approx. 90 cm

Suitable accessories:*

Order number

L-shaped mounting bracket

MAGAC-L300-----

Z-shaped mounting bracket

MAGAC-Z300-----

L-shaped mounting bracket with hood

MAGAC-K300-----

Universal Z-shaped mounting bracket

MAGAC-U300/500-

Suitable accessories:*

Order number

L-shaped mounting bracket

MAGAC-L300ST---

Z-shaped mounting bracket

MAGAC-Z300ST---

L-shaped mounting bracket with hood

MAGAC-K300-----

Universal Z-shaped mounting bracket

MAGAC-U300/500-

*** More information on accessories from page 16 onwards.**



Model MAG-03000ALM--D

Order number

Glass door adhesive housing, 10 mm

MAGAC-G300-10--

Glass door adhesive housing, 12 mm

MAGAC-G300-12--

Mounting plate

MAGAC-M300-----



Model MAG-03000STS--A

Order number

Glass door adhesive housing, 10 mm

MAGAC-G300-10--

Glass door adhesive housing, 12 mm

MAGAC-G300-12--

Mounting plate

MAGAC-M300-----

**A contact is integrated in the magnet for lock monitoring (Hall sensor)

ELECTRO HOLDING MAGNETS

TWIN MINI MAGNETS

2 X 3000 N

Utilisation

- For locking double-winged doors
- Holding power approx. 2 x 3000 N

Version for surface mounting

Dimensions (L x W x H): 500 x 42 x 25 mm

Aluminium housing surface

Order number

MAGD03000ALS--D

Aluminium housing surface, hall sensor**

MAGD03000ALS-HD



Modell MAGD03000ALS--D

Technical data

Holding power	approx. 2 x 3000 N
Rated operating voltage	12 or 24 V DC
Current consumption 12 V DC	500 mA
24 V DC	250 mA

10

Suitable accessories:*

L-shaped mounting bracket

Order number

MAGAC-L300-----

Z-shaped mounting bracket

MAGAC-Z300-----

Mounting plate for fixing counter-holding plates

MAGAC-M300-----

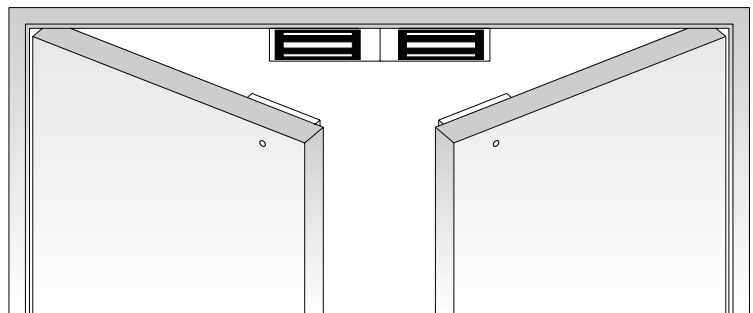

Mounting example

Note for ordering:

Two mounting brackets/mounting plates should be ordered for each magnet.

*** More information on accessories from page 16 onwards.**

**A contact is integrated in the magnet for lock monitoring (Hall sensor)

ELECTRO HOLDING MAGNETS

5000 N

MAXI MAGNETS

Utilisation

- For locking double-winged doors
- Holding power approx. 5000 N

Version for surface mounting

Dimensions (L x W x H): 266 x 68 x 40 mm

Aluminium housing surface

Order number

MAG-05000ALS--D

Aluminium housing surface, hall sensor**

MAG-05000ALS-HD

Aluminium housing sensor, hall sensor**, with time delay setting (1 to 15 seconds after power switch-off)

MAG-05000ALS-TD

Technical data

Holding power	approx. 5000 N
Rated operating voltage	12 or 24 V DC
Current consumption 12 V DC	500 mA
24 V DC	250 mA

Version for surface mounting

Dimensions (L x W x H): 220 x 68 x 41 mm

Stainless steel housing surface

Order number

MAG-05000STS--A

Stainless steel housing surface, hall sensor**

MAG-05000STS-HA

Technical data

Holding power	approx. 5000 N
Rated operating voltage	12 V DC
Current consumption	12 V DC 500 mA
Connection lead	approx. 90 cm

Suitable accessories:*

L-shaped mounting bracket

Order number

MAGAC-L500-----

Z-shaped mounting bracket

MAGAC-Z500-----

Mounting plate for fixing counter-holding plates

MAGAC-M500-----

Multi-purpose mounting plate

MAGAC-U300/500-



Model MAG-05000ALS--D

11

Suitable accessories:*

L-shaped mounting bracket

Order number

MAGAC-L500ST---

Z-shaped mounting bracket

MAGAC-Z500ST---

Mounting plate for fixing counter-holding plates

MAGAC-M500-----



Model MAG-05000STS--A

*** More information on accessories from page 16 onwards.**

**A contact is integrated in the magnet for lock monitoring (Hall sensor)

ELECTRO HOLDING MAGNETS

TWIN MAXI MAGNETS

2 x 5000 N

Verwendung für 2-flügelige Türen

- For locking doors
- Holding power approx. 2 x 5000 N

Version for surface mounting

Dimensions (L x W x H): 530 x 68 x 40 mm

Aluminium housing surface

Order number

MAGD05000ALS--D

Aluminium housing surface, hall sensor**

MAGD05000ALS-HD



Model MAGD05000ALS--D

Technical data

Holding power	approx. 2 x 5000 N
Rated operating voltage	12 or 24 V DC
Current consumption 12 V DC	500 mA
24 V DC	250 mA

12

Suitable accessories*

L-shaped mounting bracket

Order number

MAGAC-L500-----

Z-shaped mounting bracket

MAGAC-Z500-----

Mounting plate for fixing counter-holding plates

MAGAC-M500-----

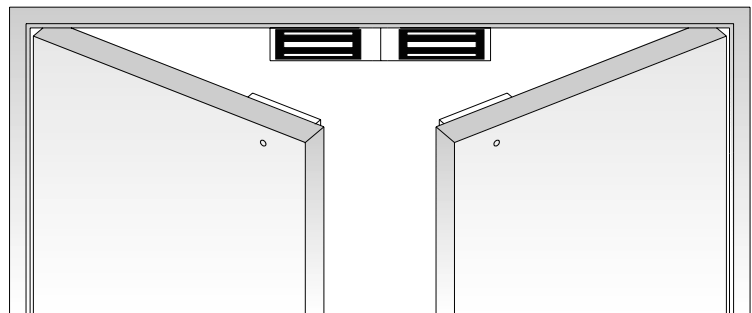

Mounting example

Note for ordering:

Two mounting brackets/mounting plates should be ordered for each magnet.

*** More information on accessories from page 16 onwards.**

**A contact is integrated in the magnet for lock monitoring (Hall sensor)

ELECTRO HOLDING MAGNETS

6500 N

WATER PROTECTED

DOOR & GATE MAGNETS

Utilisation

- For locking doors and gates outdoors
- Holding power approx. 6500 N

Version for surface mounting

Dimensions (L x W x H): 220 x 68 x 41 mm

Stainless steel housing surface

Order number

MAGG06500STS--D

Stainless steel housing surface, hall sensor**

MAGG06500STS-HA

Stainless steel housing surface, hall sensor**

MAGG06500STS-HB



Model MAGG06500STS-HA

Technical data

Holding power	approx. 6500 N
Rated operating voltage	
MAGG06500STS--D	12 or 24 V DC
MAGG06500STS-HA	12 V DC
MAGG06500STS-HB	24 V DC
Current consumption	
12 V DC	500 mA
24 V DC	250 mA
Schutzart	IP 65
Connection lead	approx. 90 cm

13

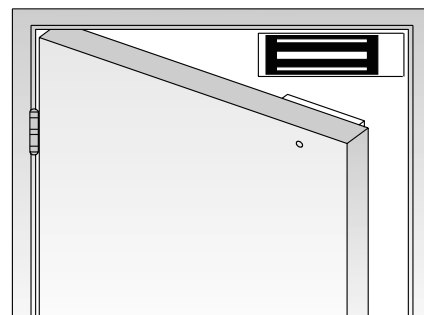

Mounting example

Suitable accessories:*

L-shaped mounting bracket

Order number

MAGAC-L1200----

*** More information on accessories from page 16 onwards.**

**A contact is integrated in the magnet for lock monitoring (Hall sensor)

ELECTRO HOLDING MAGNETS

MINI SHEAR MAGNETS

5700 N

Shear magnet function

The magnet counter plates are attracted when the magnets are energised, causing the locking pins on the counter-holding plate in the electro holding magnets to close. This increases the mechanical locking forces.

Utilisation

- For locking doors
- For installation in door frame and leaf
- The positive locking function increases retaining forces

Version for surface mounting

Dimensions of magnet + counter unit (L x W x H): 175 x 35 x 44 mm

Aluminium housing surface, black surface-mounted housing

Order number

MAGS05700ALS1-D

Aluminium housing surface, hall sensor**

MAGS05700ALS1HD



Model MAGS05700ALS1-D



Model MAGS05700ALMI-D

Version for mortise mounting

Dimensions of magnet (L x W x H): 180 x 30 x 27 mm

Dimensions of counter unit (L x W x H): 180 x 30 x 42 mm

Aluminium housing surface

Order number

MAGS05700ALM1-D

Aluminium housing surface, hall sensor**

MAGS05700ALM1HD

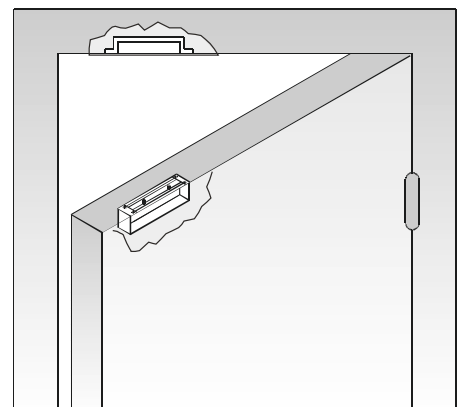

Mounting example

Technical data

Holding power/Shearing force	approx. 5700 N
Rated operating voltage	12 or 24 V DC
Current consumption	12 V DC: 350 mA 24 V DC: 190 mA
Magnet/Counter plate distance	min. 2 mm / max. 3 mm

**A contact is integrated in the magnet for lock monitoring (Hall sensor)

ELECTRO HOLDING MAGNETS

15000 N

MAXI SHEAR MAGNETS

Utilisation

- For locking doors
- For installation in door frame and leaf
- The positive locking function increases retaining forces

Version for mortise mounting

Aluminium housing surface, hall sensor,
with time delay setting (2 to 6 seconds after deactivation)

30 mm wide face plate

Dimensions of magnet + counter unit (L x W x H): 267 x 30 x 40 mm

Order number

MAGSI5000ALM1TD

Aluminium housing surface, hall sensor,
with time delay setting (2 to 6 seconds after deactivation)

35 mm wide face plate

Dimensions of magnet + counter unit (L x W x H): 267 x 35 x 40 mm

Order number

MAGSI5000ALM2TD



Model MAGSI5000ALM1TD

15

Technical data	
Holding power/Shearing force	approx. 15000 N
Rated operating voltage	12 to 28 V DC stabilised autom. voltage detection and adaptation
Current consumption 12 V DC 28 V DC	1800 mA (pull-in) 500 mA (holding)
Dimensions ...ALM1TD Magnet / Counter unit (L x W x D)	267 x 30 x 40 mm
Dimensions ...ALM2TD Magnet / Counter unit (L x W x D)	267 x 35 x 40 mm
Magnet/Counter plate distance	min. 2 mm / max. 3 mm

Suitable accessories*

Installation housing for ALMD1 and ALMD2

Order number

MAGACSK150035--

Power supply unit (regulated), 230 V AC / 24 V DC / 1 A

1003-24-1----00

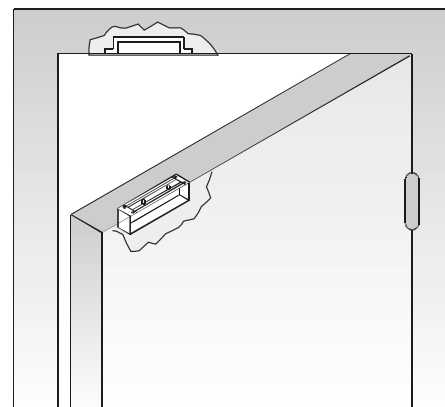

Mounting example

*** More information on
accessories from page 16
onwards.**

**A contact is integrated in the
magnet for lock monitoring
(Hall sensor)

ELECTRO HOLDING MAGNETS

ACCESSORIES

L-SHAPED MOUNTING BRACKET

L-shaped mounting brackets

For mounting on flush-surface door elements. For outwards-opening doors.

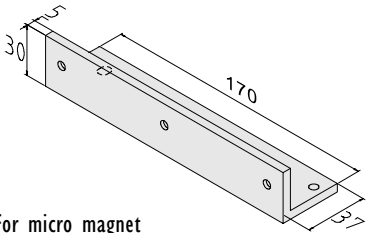

For micro magnet

MAGAC-L150-----

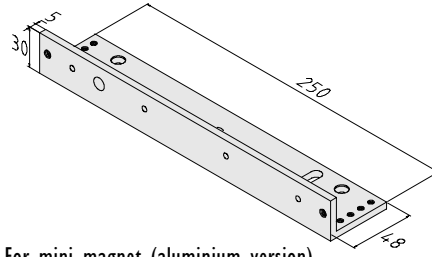

For mini magnet (aluminium version)

MAGAC-L300-----

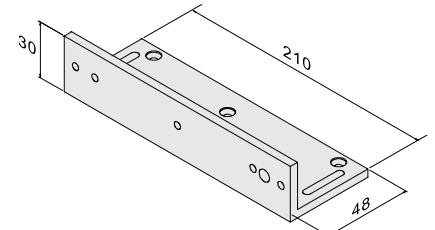

For mini magnet (stainless steel version)

MAGAC-L300ST---

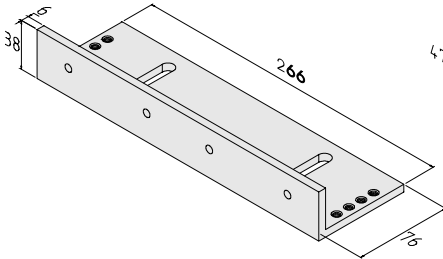

For maxi magnets (aluminium version)

MAGAC-L500-----

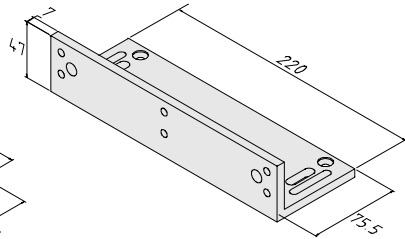

For maxi magnet (stainless steel version)

MAGAC-L500-ST--

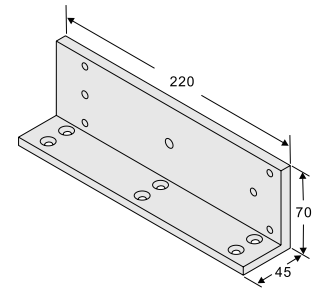

For gate magnets for sliding doors

MAGAC-L1200----

16

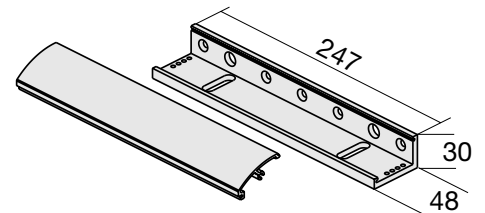

Mounting bracket for mini magnet
L-shaped with hood

MAGAC-K300-----

Installation drawing for
**L-shaped
mounting bracket**

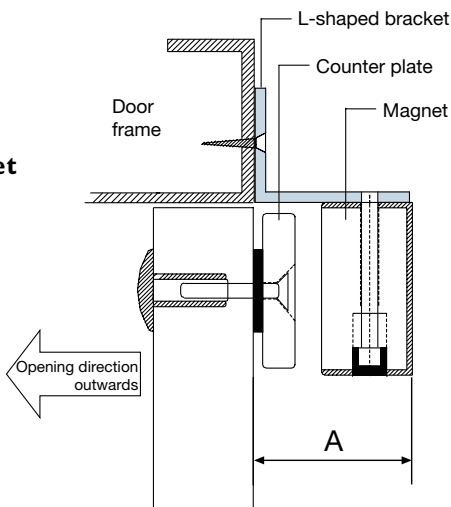

Variable dimension "A"
Mounting bracket

Dimension

MAGAC-L150	38 mm
MAGAC-L300	48/42/36/30 mm
MAGAC-L300ST	48 - 30
MAGAC-K300	48/42/36/30 mm
MAGAC-L500	77/65/53/41 mm
MAGAC-L500-ST	77 - 41 mm

ELECTRO HOLDING MAGNETS

Z-SHAPED MOUNTING BRACKET

ACCESSORIES

Z-shaped mounting brackets

For mounting on flush-surface door elements. For inwards-opening doors.

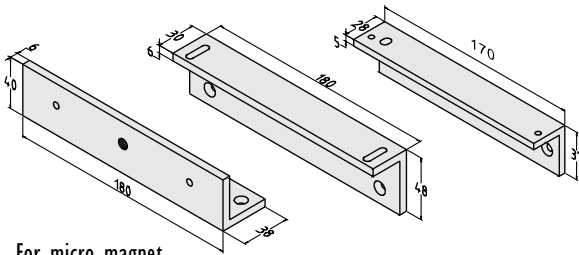

For micro magnet

MAGAC-Z150-----

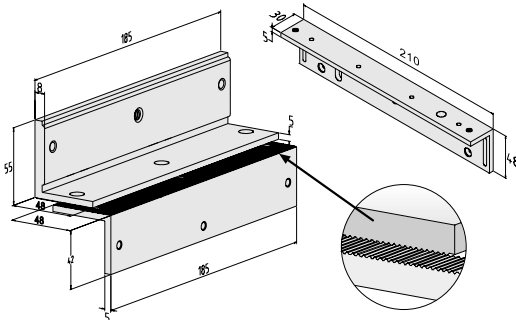

For mini magnet (stainless steel version)

MAGAC-Z300ST---

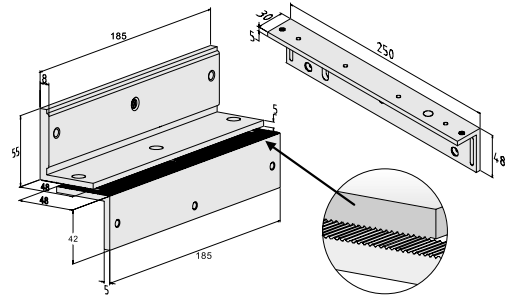

For mini magnet (aluminium version)

MAGAC-Z300-----

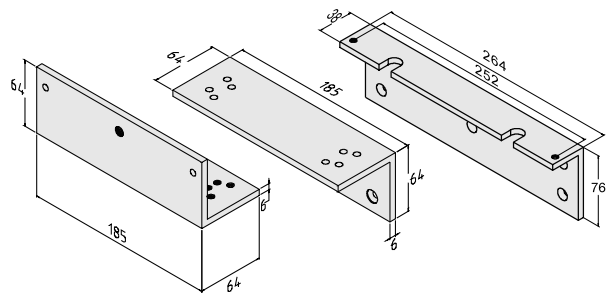

For maxi magnets (aluminium version)

MAGAC-Z500-----

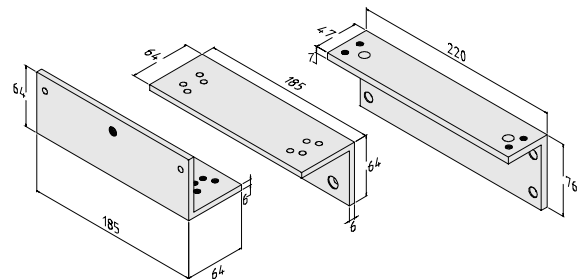

For maxi magnet (stainless steel version)

MAGAC-Z500ST---

Installation drawing for Z-shaped mounting bracket

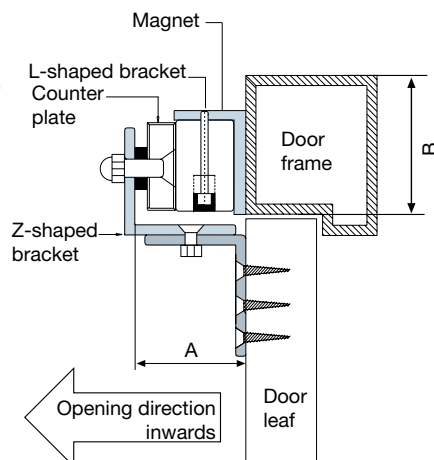

Variable dimension "A"

Mounting bracket	Dimension A	Dimension B
MAGAC-Z150	32 - 43 mm	37 mm
MAGAC-Z300	40 - 57 mm	48 mm
MAGAC-Z300ST	40 - 57 mm	48 mm
MAGAC-Z500 / MAGAC-Z500-ST	70 mm	76 mm

ELECTRO HOLDING MAGNETS

ACCESSORIES

MOUNTING PLATES

Mounting plates

Used everywhere where one-piece screw fitting of counter-holding plates is not possible (e.g. on wooden doors).

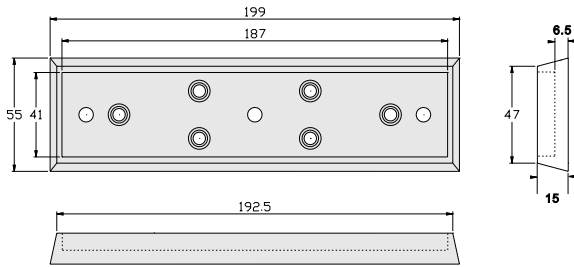

Mounting plate for fixing counter-holding plates (3000N series)

MAGAC-M300-----

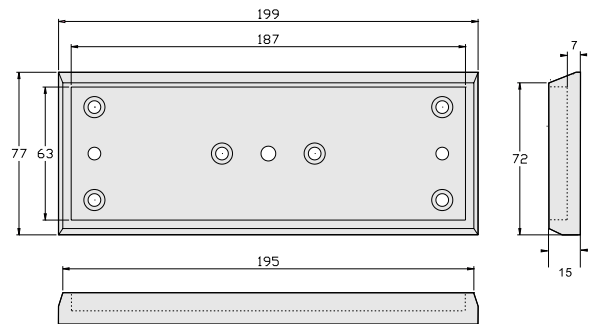

Mounting plate for fixing counter-holding plates (5000N series)

MAGAC-M500-----

18

Installation drawing for
Mounting plate

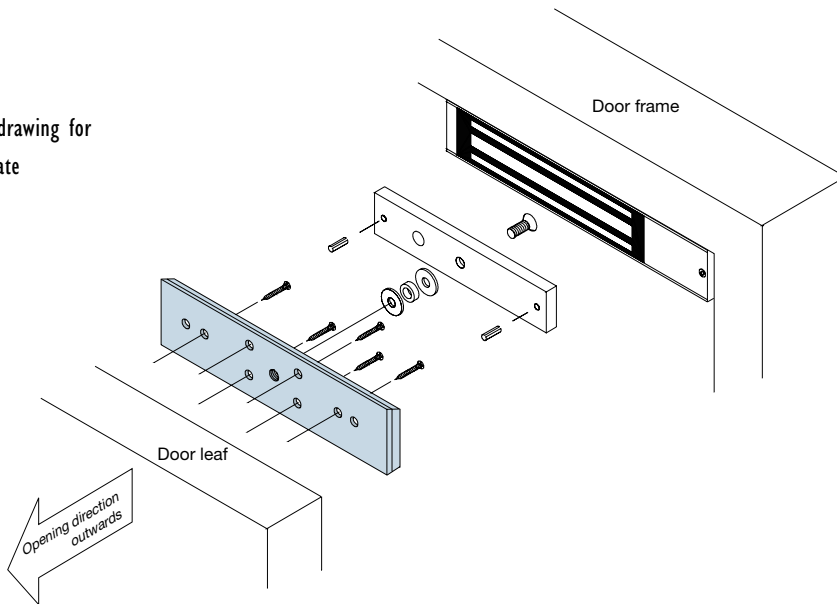

ELECTRO HOLDING MAGNETS

MOUNTING PLATES, HOUSING

ACCESSORIES

Adhesive housing

for mounting on glass door elements

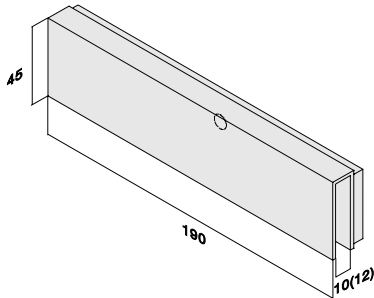

Glass door adhesive housing

for mounting counter-holding plate on glass door element
for glass thickness 10 mm

MAGAC-G300-10--

for glass thickness 12 mm

MAGAC-G300-12--

Klebeset für Klebmontage

843-8-----00

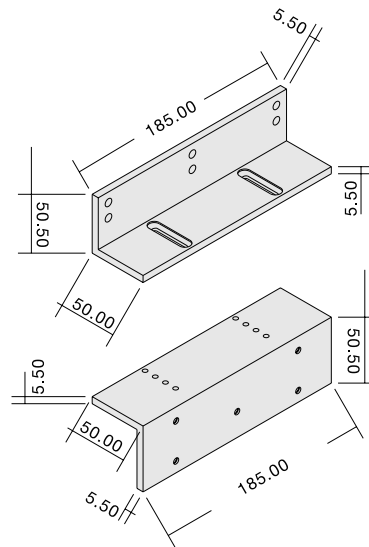

Multi-purpose mounting plate

for fixing counter-holding plate

Variable dimension A: 51 - 72 mm

(See illus. on page 17 for dimensions A)

MAGAC-U300/500-

Installation drawing for
mounting with adhesive housing

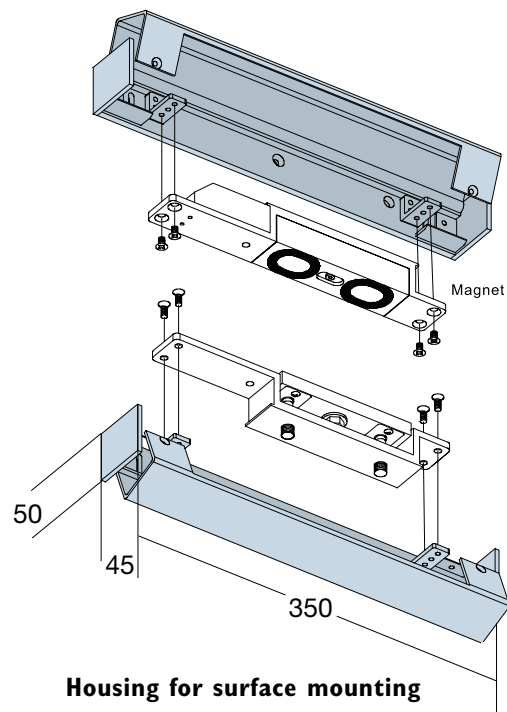
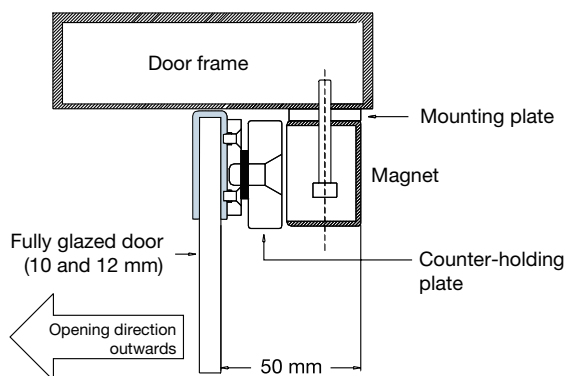

Housing for surface mounting

for surface mounting of maxi shear magnets

MAGACSL150035--

ELECTRO HOLDING MAGNETS

MAGNETS

ON RESCUE ROUTES



Employees, hotel guests or visitors in public buildings should feel assured that there is an evacuation possibility during an emergency, and escape routes offer this possibility. Doors on escape routes should open easily and without auxiliary assistance during an evacuation. However, this generally contradicts the need for security felt by building operators, as misuse of emergency exits provides a means of access. For example, emergency exits in supermarkets offer people the option of bypassing the checkout.

The Building Regulation List defines a product to meet these requirements under “electrical locking systems for doors on escape routes”. This enables a safe evacuation in every case of emergency and simultaneously prevents abuse of emergency exits.

All effeff escape door systems meet the defining technical requirement for this product specified in Building Regulation List A, part I consec. no. 6.19 as the “Directive for electrical locking systems on escape route doors (EltVTR)” and bear the corresponding symbol (Ü symbol).

The systems and their components

Only three components are required for securing doors on escape routes with effeff escape door systems in compliance with regulations, as the control electronics are already integrated in the terminal.

Central systems (e.g. building control technology, hazard warning systems, etc.) can be connected to the control electronics. The panel for centralised monitoring and control is realised with BUS technology.

Closed-circuit current principle

Systems for securing escape routes function on the closed-circuit current principle. The door is enabled immediately in the event of activation, emergency unlocking or a power failure.

effeff surface holding magnets are approved by EltVTR and utilised if doors in fire barriers with escape door systems need to be retrofitted, or if no measurable constructional alteration should occur to door leafs and frames after subsequent fitting of an escape door system. In addition, the practically silent functionality of surface holding magnets is an advantage where frequently used doors are involved. Surface holding magnets involve the activation of an integrated hall sensor which sends the required feedback signal to the control unit, thus also ensuring that the system is protected against sabotage and manipulation.

Our “Escape route technology” brochure contains further information and a detailed overview of products.



ELECTRO HOLDING MAGNETS

2500 N

COMPACT SURFACE HOLDING MAGNETS

Surface holding magnets approved for use on escape routes

Surface holding magnets are suitable for electro-magnetic locking of doors. They are easily installed, and alterations or incisions on door frames are unnecessary. According to a letter dated the 24th of March 1991 from the Institute for Civil Engineering (Institut für Bautechnik), Berlin, electro holding magnets can also be fitted to fire protection doors. The following models 827 and 828 have been issued with Building Monitoring Authority approval in accordance with EltVTR and can therefore be utilised for doors on escape and rescue routes.

Compact surface holding magnets 827 Comprehensive security for doors on escape routes

Compact surface holding magnets. No monitoring contacts, with a counter-holding plate in a slim unit design for integration in door frames, sturdy shape-retaining aluminium housing for flush mounting.

Naturally-coloured anodised housing surface finish

Dimensions of magnet (L x W x H): 301 x 28 x 35 mm

Dimensions of counter unit (L x W x H): 301 x 20 x 35 mm

Order number

827-----44F90

Suitable accessories

Magnet contacts (see escape route technology brochure)

Order number

10365-6-----00

Compact surface holding magnets 827 aP In mounting housing (e.g. for sliding doors)

Complete with counter-holding plate is surface-mounted housing, sturdy shape-retaining design in aP sheet-steel housing, grey-white colour finish

Dimensions (L x W x H): 301 x 52 x 43 mm

Order number

827AP-----93F90

Suitable accessories

Reed contacts (see escape route technology brochure)

Order number

10365-6-----00

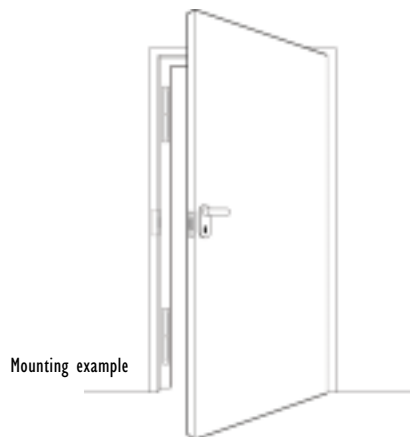

Mounting example



Model 827-----44F90



Model 827AP-----93F90

Technical data

Rated operating voltage	24 V DC/12 V DC
Current consumption	250 mA/500 mA
Nominal output	6 W
Duty cycle	100 % ED
Holding power	2500 N
Residual holding power	0 N
Connection lead length	4 m

ELECTRO HOLDING MAGNETS

COMPACT SURFACE HOLDING MAGNETS

5000 N

Surface holding magnets approved for use on escape routes

Surface holding magnets are suitable for electro-magnetic locking of doors. They are easily installed, and alterations or incisions on door frames are unnecessary. According to a letter dated the 24th of March 1991 from the Institute for Civil Engineering (Institut für Bautechnik), Berlin, electro holding magnets can also be fitted to fire protection doors. The following models 827 and 828 have been issued with building monitoring authority approval in accordance with EltVTR and can therefore be utilised for doors on escape and rescue routes.

Surface holding magnet 828

The rated voltage can be set to 24 V DC or 12 V DC on the magnet. The counter-holding plate 828-2 is included in the scope of delivery. The electro surface holding magnet 828 contains an integrated contact for the locking sensor (hall sensor).



Model 828-----44F90

Naturally-coloured anodised housing surface finish

Dimensions of magnet (L x W x H): 287 x 37,5 x 68 mm

Dimensions of counter unit (L x W x H): 200 x 27 x 60 mm

Order number

828-----44F90

Dark bronze anodised housing surface finish

828-----47F90

Please note when ordering:

In addition to the integrated locking sensor, a secondary door contact is required.

Technical data

Rated operating voltage	24 V DC / 12 V DC
Current consumption	315 mA / 630 mA
Nominal output	7,5 W
Switch-on time	100 % ED
Holding power	5000 N
Residual holding power	0 N
Switching contact	Floating relay change-over contact Max. switching current 2 A resistive load

Suitable accessories

Mounting set 828-6

For mounting the surface holding magnet 828 on flush-surface door elements. The set consists of an adjustable mounting bracket, mounting bracket 828-4 and plastic cover.

Order number

828-6-----44

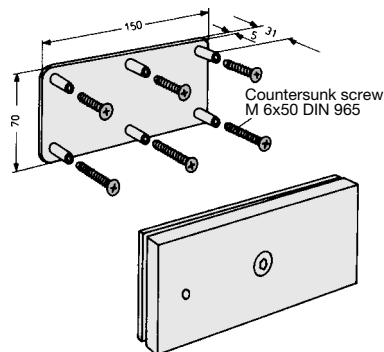

The mounting counter holders 828-5 are utilised for enabling one-piece screw mountings on wooden doors. Greater stability is thus achieved when the counter-holding plate is secured to wooden doors (not suitable for fire protection doors).

Mounting counter holder 828-5

For the counter-holder plate 828-2. Supplied complete with mounting screws (M 6x50 DIN 965 countersunk screws).

Dimensions 150x70 mm.

Threaded sleeve length 31 mm.

Order number

828-5-----44

Mounting bracket 828-7

For mounting the surface holding magnet 828 on flush-surface door elements. Complete with spacer plates and fixed counter piece.

Order number

828-7-----00

ELECTRO HOLDING MAGNETS



24



Round magnets (e.g. for door arrester systems)

The comprehensive range of effeff magnets covers all types of application. Whether for mounting on the wall or the floor with appropriate spacers – effeff is your competent partner, world wide.

Holding magnets with diodes

Magnets for integration in fire alarm systems and other electrical systems can be supplied with a built-in recovery and polarity reversal protection diode.

Order supplement ... with diode

Holding magnets and mating plates

Are made of special magnetic soft iron. This ensures optimum adhesion with low power consumption and slight residual adhesion.

Magnets and mating plates must therefore always be ordered together. The surfaces of the magnets and mating plates are nickel plated.

The magnets may be combined with attachment housings and spacers.

Ease of mounting

The mating plates are always larger in diameter than the corresponding magnets. This makes it easier to adjust to the magnet when mounting the mating plate, because the excess size of the plate takes the mounting tolerances into account.

Our “Door arrester systems” brochure contains further information and a detailed overview of products.



ELECTRO HOLDING MAGNETS

ROUND MAGNETS FOR HOLDING DOORS OPEN

Example of wall mounting



Counter-holding plate:
Model 838-2

Holding magnet:
Model 838 A with mounting plate and
covered connecting terminal

Example of floor mounting



Counter-holding plate:
Model 838-2

Holding magnet:
Model 838/839 BW I spacer



Counter-holding plate:
Model 838-2

Holding magnet:
Model 838/839 BW 2U



Counter-holding plate:
Model 838-2

Holding magnet:
Model 838 iGW in cast aluminium housing



Counter-holding plate:
Model 838-2

Holding magnet:
Model 838 iGB in cast aluminium housing

ELECTRO HOLDING MAGNETS

ROUND MAGNETS FOR HOLDING DOORS OPEN

Magnets

Version A

With mounting plate and concealed connection terminal.

Version BC

Cable connection changeable to side or back.

Back connection with 2 x M5 screws for spacer or building-side holder.

Series 837

Adhesion 300 N

Model 837 A

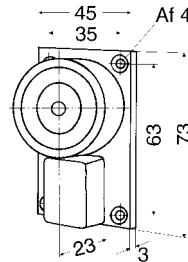

Order number

837A-----F90

Model 837 BC

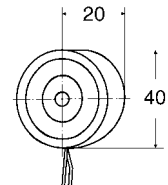

Order number

837BC-----F90

Series 838

Adhesion 800 N

Model 838 A

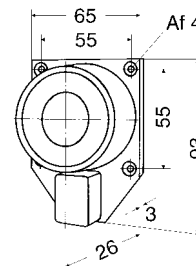

Order number

838A-----F90

Model 838 BC

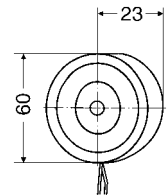

Order number

838BC-----F90

Series 858

Adhesion 1800 N

Model 858 A

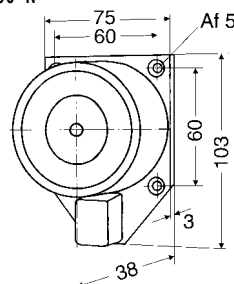

Order number

858A-----F90

Model 858 BC

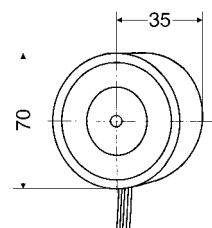

Order number

858BC-----F90

Technical data			
	Model 837...	Model 838...	Model 858...
Operating voltage	24 V DC		
Nominal current consumption	approx. 0,075 A (typically)	approx. 0,09 A (typically)	approx. 0,25 A (typically)
Nominal power consumption	approx. 1,8 W (typically)	approx. 2,1 W (typically)	approx. 6 W (typically)
Switch-on time	100 % ED		
Operating temperature range	0°C to +50°C		
Operating temperature at 20°C	approx. 45°C	approx. 45°C	approx. 45°C
Fuse tape	IP 40 (acc. to DIN EN 60 529, 2000-09)		
Nominal adhesive power	up to 300 N	up to 800 N	up to 1800 N
DIBt-approval	Z 6.5-430		
Dimensions	Vary with version (see dimensioned drawing)		

Suitable counter-holding plates on page 30/31

ELECTRO HOLDING MAGNETS

ROUND MAGNETS FOR HOLDING DOORS OPEN

Holding magnets

Version iS

wall-mounting version in plastic housing

Model 838 iS without contact-breaker button

Order number

838iS-----F90

Model 838 iS/U with contact-breaker button

Order number

838iS/U-----F90

Adhesion 800 N

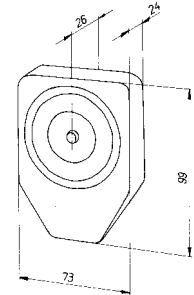

Version iGW

In aluminium housing for wall mounting

Model 838 iGW without contact-breaker button

Order number

838iGW-----F90

Model 838 iGW/U with contact-breaker button

Order number

838iGW/U-----F90

Adhesion 800 N

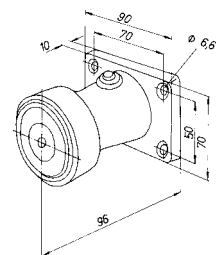

Version iGB

in aluminium housing for floor mounting

Model 838 iGB without contact-breaker button

Order number

838iGB-----F90

Model 838 iGB/U with contact-breaker button

Order number

838iGB/U-----F90

Adhesion 800 N

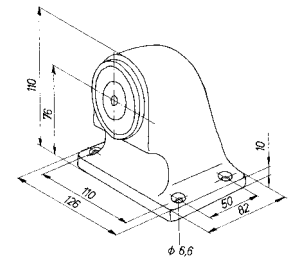

Mounting example for wall/floor mounting

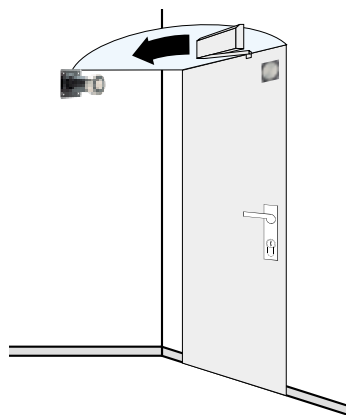

The door closer takes effect at the top, so mount the locking unit at the top.

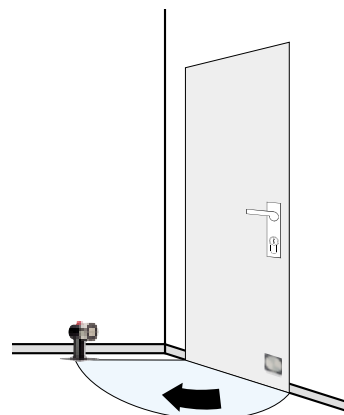

The door closer takes effect at the bottom, so mount the locking unit at the bottom.

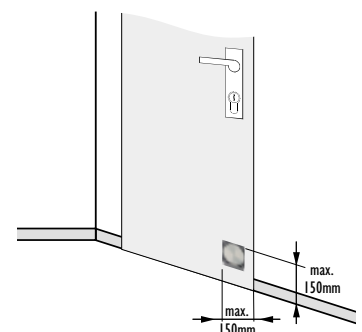

Relevant counter-holding plate mounting distance for arrester systems.

ELECTRO HOLDING MAGNETS

ROUND MAGNETS

SPACERS

Haftmagnete

Spacer 839

Convertible for floor or wall mounting.

Always order the desired model of magnet and spacer 839... together.

Spacers for floor or wall mounting

Model 837/839
without contact-breaker button
Adhesion 300 N
Order number

837/839-----F90

Model 838/839
without contact-breaker button
Adhesion 800 N
Order number

838/839-----F90

Model 837/839 U
without contact-breaker button
Order number

837/839U----F90

Model 838/839 U
without contact-breaker button
Order number

838/839U----F90

Dimensions:
Distance from wall 95 mm
Distance from floor 60 mm

Dimensions:
Distance from wall 98 mm
Distance from floor 60 mm

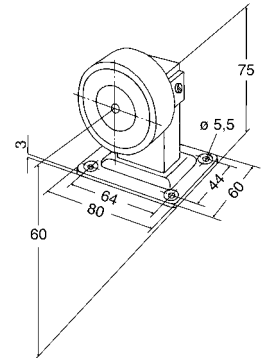

838/839

Spacer 839 BW...

The 839 BW... spacers can be modified for floor or wall mounting.

Spacer tube for mounting the magnet is available in 4 standard lengths.

Always order the desired model of magnet and spacer 839 BW... together.

Model 838/839 BW I
Adhesion 800 N
without contact-breaker button
Order number

838/839BW I--F90

Model 858/839 BW I
Adhesion 1800 N
without contact-breaker button
Order number

858/839BW I--F90

Model 838/839 BW I U
with contact-breaker button
Order number

838/839BW I U-F90

Model 858/839 BW I U
with contact-breaker button
Order number

858/839BW I U-F90

Dimensions:
Distance from wall 115 mm
Distance from floor 70 mm

Dimensions:
Distance from wall 127 mm
Distance from floor 70 mm

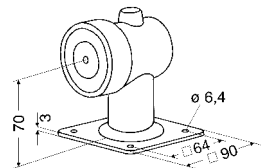

838/839 BW I U

Version .../U

with contact-breaker button

Version BW

Convertible for floor or wall mounting

Convertible for floor or wall mounting



Model 838/839 ...

... BW1U-F90

... BW2U-F90

... BW3U-F90

... BW4U-F90

ELECTRO HOLDING MAGNETS

SPACERS

ROUND MAGNETS

Model 838/839 BW 2
Adhesion 800 N
without contact-breaker button
Order number

838/839BW2--F90

Model 838/839 BW 2 U
with contact-breaker button
Order number

838/839BW2U-F90

Dimensions:
Distance from wall 155 mm
Distance from floor 110 mm

Model 858/839 BW 2
Adhesion 1800 N
without contact-breaker button
Order number

858/839BW2--F90

Model 858/839 BW 2 U
with contact-breaker button
Order number

858/839BW2U-F90

Dimensions:
Distance from wall 167 mm
Distance from floor 110 mm

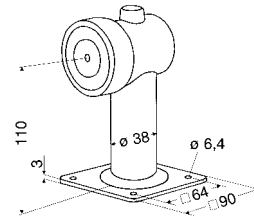

838/839 BW 2 U

Model 838/839 BW 3
Adhesion 800 N
without contact-breaker button
Order number

838/839BW3--F90

Model 838/839 BW 3 U
with contact-breaker button
Order number

838/839BW3U-F90

Abmessungen
Distance from wall 265 mm
Distance from floor 220 mm

Model 858/839 BW 3
Adhesion 1800 N
without contact-breaker button
Order number

858/839BW3--F90

Model 858/839 BW 3 U
with contact-breaker button
Order number

858/839BW3U-F90

Abmessungen
Distance from wall 277 mm
Distance from floor 220 mm

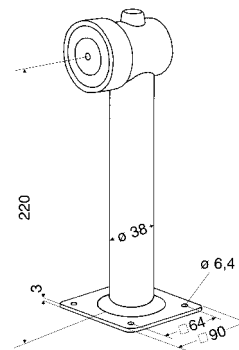

838/839 BW 3 U

Model 838/839 BW 4
Adhesion 800 N
without contact-breaker button
Order number

838/839BW4--F90

Model 838/839 BW 4 U
with contact-breaker button
Order number

838/839BW4U-F90

Dimensions:
Distance from wall 395 mm
Distance from floor 350 mm

Model 858/839 BW 4
Adhesion 1800 N
without contact-breaker button
Order number

858/839BW4--F90

Model 858/839 BW 4 U
with contact-breaker button
Order number

858/839BW4U-F90

Abmessungen
Distance from wall 407 mm
Distance from floor 350 mm

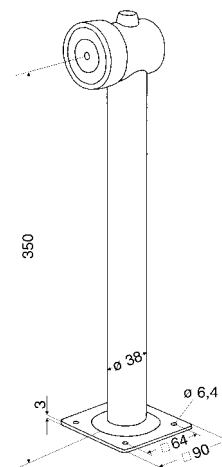

838/839 BW 4 U

ELECTRO HOLDING MAGNETS

ROUND MAGNETS

COUNTER-HOLDING PLATES

Counter-holding plates

Mounting plate with articulated counter-holding plate

Model 837-2

Order number **837-2-----00**

Model 838-2

Order number **838-2-----00**

Model 858-2

Order number **858-2-----00**

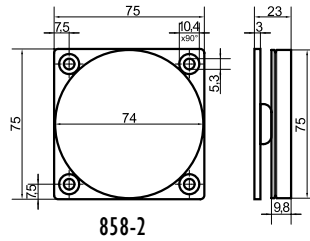
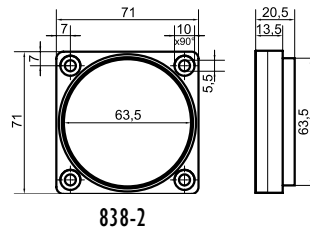
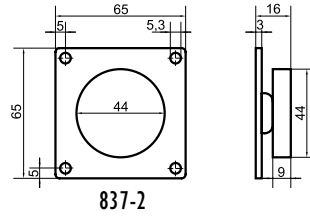

30

Counter-holding plate on mounting housing with spring damper for gentle, sprung closing of heavy doors

Model 837-2P

Order number **837-2P-----00**

Model 838-2P

Order number **838-2P-----00**

Model 858-2P

Order number **858-2P-----00**

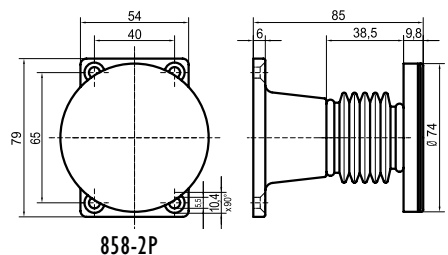
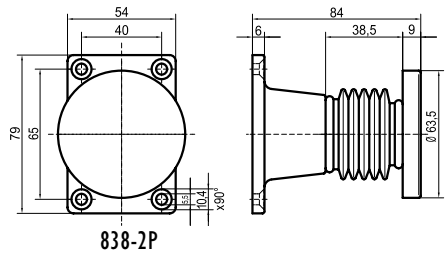
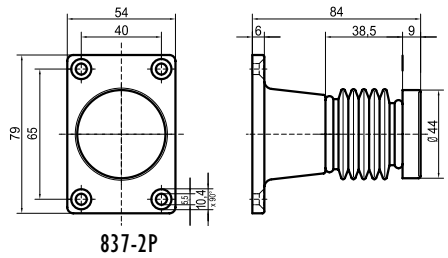

ELECTRO HOLDING MAGNETS

COUNTER-HOLDING PLATES

ROUND MAGNETS

Counter-holding plates on mounting plate, adjustable for extreme angles between door and magnet

Model 837-3

Order number **837-3-----00**

Model 838-3

Order number **838-3-----00**

Model 858-3

Order number **858-3-----00**

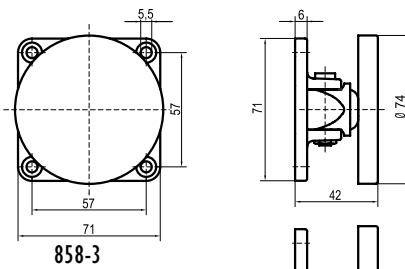
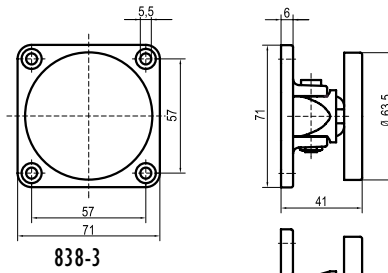
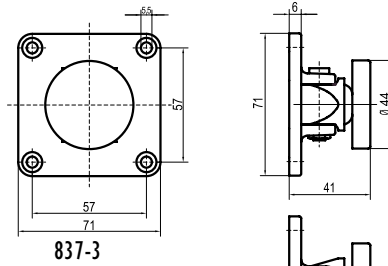

ELECTRIC DOOR STRIKE

effeff door strikes offer a high degree of security and are easy to use. Our wide range fulfils all requirements and includes models for all types of installation.

This applies worldwide as effeff products comply with both national and international regulations. effeff's convincing solutions for smoke protection doors, fire rated doors and doors in escape routes.



ELECTRIC BOLTS

effeff electric bolts reliably complement locks and door strikes and are used for special applications e.g. swing doors or sliding doors where they act as an additional locking mechanism. For door bolts with integrated monitoring contact, the locking state can be monitored so that e.g. a system can only start when the corresponding door is also securely locked.

Application possibilities range from the simple drawer to elevator doors and high security zones.



ESCAPE DOOR SYSTEMS

When danger is imminent have confidence in effeff's know-how and reliability. Our rescue path systems ensure secure operation of the escape route door irrespective of whether the door requires locking or may only be used by authorized persons. Absolute secure use of escape routes in case of danger is ensured at all times.

effeff escape door control systems ensure protection and security e.g. in hospitals, schools, kindergarten, office buildings, airports and exhibition halls. For your special applications too, we have the fitting solutions e.g. closed departments in clinics.



SECURITY LOCKS

First and foremost security: The effeff electric security locks with anti-panic function and self-locking mechanism ensure maximum mechanical security in conjunction with high operating comfort for the user. The effeff range of locks is suitable for use both in fire doors and escape and rescue routes.



Product Overview

ELECTRO HOLDING MAGNETS

A wide variety of magnets is an integral part of the effeff range of locking mechanisms.

Thanks to the virtually silent function and special advantages of subsequent mounting, magnets present an excellent additional locking mechanism. The outstanding feature of the effeff magnets is the high-quality surface and attractive design.



DOOR AUTOMATICS

It is hard to imagine many buildings today without automatic power-operated doors. They facilitate free entry without barriers and thus simultaneously save energy. The effeff electromechanical and electrohydraulic swing door operators for one and two leaf swing doors are suitable for both private and commercial areas of application.



ACCESS CONTROL SYSTEMS

The simple solution for maximum security! effeff access control systems protect and monitor buildings, individual rooms or other security-relevant zones.

effeff offers a wide range of varying technologies, devices and systems that are aligned to the special security requirements. effeff access control systems meet the special requirements of our customers and are used in private, official and industrial zones.



AUTOMATIC DOOR ARRESTER SYSTEMS

effeff automatic door arrester systems secure fire-retardant doors that must remain open for daily use. As soon as smoke is signalled, the arrester mechanism releases the door. The fire doors close and prevent fire and smoke gases from reaching adjoining rooms and buildings and fire from spreading.



Électro-aimants de fixation

Elettromagneti di ritenuta

Elektro-Haftmagnete

Electro holding magnets

Electroimanes adherentes

ASSA ABLOY
Sicherheitstechnik GmbH
Bildstockstraße 20
72458 Albstadt
GERMANY
Tel. +49 7431 123-0
Fax +49 7431 123-240
albstadt@assaabloy.de
www.assaabloy.de



effeff, established in 1936 as a precision engineering and electrical engineering workshop, has developed through the implementation of a consistent product policy to become the global market leader in the field of electromechanical locking device technology. Electrical door releases, electrical bolts, safety locks, access control systems, electrical magnets, escape route technology, revolving door drives, fire protection door arrester systems and control elements are among the products that effeff, based in Albstadt on the Swabian Alb, Germany, exports today to 75 countries around the globe.

IKON, established in 1926 as ZEISS IKON AG, is one of the leading manufacturers of locking cylinders, locks and locking systems in Germany. Our products and solutions are manufactured to state-of-the-art technological standards and also include (for some time now) mechatronic locking cylinders, access control systems, escape door technology, door fittings and door closing mechanisms, along with numerous auxiliary locks and securing devices. They protect both people and valuables.

ASSA ABLOY Sicherheitstechnik GmbH. The brands IKON and effeff have developed, produced and marketed in a joint company since 2005, perfectly complementing the two different product ranges produced by both firms. This enables us to offer our customers comprehensive and complex solutions for private, commercial and public service applications.

ASSA ABLOY is the world's leading manufacturer and supplier of locking system solutions and security systems that meet the highest demands of our customers when it comes to security, protection and user-friendliness. With approximately 30,000 employees, the group achieves a turnover of approximately 3 thousand million Euros annually.